



**SPARTAN
EQUIPMENT®**

OPERATOR'S AND PARTS MANUAL

205 Series

SE Hopper Broom



Serial Number: _____

Model Number: _____

Manual Number: 51-4178
Release Date: January 2014
Serial Number: 0913001 & Up
Rev. 1

Notes

TABLE OF CONTENTS

INTRODUCTION	4
SAFETY STATEMENTS	4
GENERAL SAFETY PRECAUTIONS	5-6
SAFETY SIGNS & LABELS	7
SERVICE & REPAIR - SAFETY	8
OPERATION	8
STORAGE	10
PRODUCT INFORMATION	11
MAINTENANCE	12
REPLACING BRUSH SECTIONS	13
MAINTENANCE SCHEDULE	14
MAINTENANCE RECORD	15
TROUBLESHOOTING	16-17
ADJUSTING THE GUTTERBROOM	18
CORE ASSEMBLY	20
MOTOR ASSEMBLY	21
BEARING ASSEMBLY	22-23
HOODASSEMBLY	24
CUTTING EDGE KIT	25
GUTTERBROOM	26-27
DUST SUPPRESSION KIT	28-29
BOLT TORQUE SPECIFICATIONS	30
HYDRAULIC TORQUE SPECIFICATIONS	31-32
WARRANTY	33

INTRODUCTION

SAFETY STATEMENTS

Purpose of Sweeper

This sweeper is designed solely for the use in construction cleanup, road maintenance and similar operations. Use in any other way is considered contrary to the intended use. Compliance with and strict adherence to operation, service and repair conditions, as specified by the manufacturer, are also essential elements of the intended use.

Contacting Spartan Equipment

If you have any questions about information in this manual or need to order parts, please call, write, fax or e-mail SPARTAN EQUIPMENT.

Spartan Equipment
PO Box 50
Joppa, Maryland 21085
Phone: 1-888-888-1085
e-mail: contact@spartanequipment.com

For help with installation, operation or maintenance procedures, contact our Technical Service Department. Direct product questions and parts orders to our Sales Department.

When ordering parts or accessories, be prepared to give the following information:

- Sweeper model, serial number and date of purchase
- Prime mover, make and model
- Part number, description and quantity

Terms Used in Manual

Right-hand, left-hand, front and rear are determined from the operator's perspective (either the operator's seat or standing behind a walk-behind unit), facing forward in the normal operating position.

Warranty

To validate the warranty for this unit, fill out the warranty card or warranty pages located in the back of this manual. Then send this information to SPARTAN.

DANGER!



THIS STATEMENT IS USED WHERE SERIOUS INJURY OR DEATH WILL RESULT IF THE INSTRUCTIONS ARE NOT FOLLOWED PROPERLY.

WARNING!



THIS STATEMENT IS USED WHERE SERIOUS INJURY OR DEATH COULD RESULT IF THE INSTRUCTIONS ARE NOT FOLLOWED PROPERLY.

CAUTION!



THIS STATEMENT IS USED WHERE MINOR INJURY COULD RESULT IF THE INSTRUCTIONS ARE NOT FOLLOWED PROPERLY.

NOTICE!

THIS STATEMENT IS USED WHERE EQUIPMENT OR PROPERTY DAMAGE COULD RESULT IF THE INSTRUCTIONS ARE NOT FOLLOWED PROPERLY.



THIS SYMBOL BY ITSELF OR USED WITH A SAFETY SIGNAL WORD THROUGHOUT THIS MANUAL IS USED TO CALL YOUR ATTENTION TO INSTRUCTIONS INVOLVING YOUR PERSONAL SAFETY OR THE SAFETY OF OTHERS. FAILURE TO FOLLOW THESE INSTRUCTIONS CAN RESULT IN INJURY OR DEATH.

GENERAL SAFETY PRECAUTIONS GENERAL SAFETY PRECAUTIONS

WARNING!



READ MANUAL PRIOR TO INSTALL

Improper installation, operation, or maintenance of this equipment could result in serious injury or death. Operators and maintenance personnel should read this manual as well as all manuals related to this equipment and the prime mover thoroughly before beginning installation, operation, or maintenance. **FOLLOW ALL SAFETY INSTRUCTIONS IN THIS MANUAL AND THE PRIME MOVERS MANUAL.**

WARNING!



READ AND UNDERSTAND ALL SAFETY STATEMENTS

Read all safety decals and safety statements in all manuals prior to operating or working on this equipment. Know and obey all OSHA regulations, local laws and other professional guidelines for your operation. Know and follow good work practices when assembling, maintaining, repairing, mounting, removing or operating this equipment.



KNOW YOUR EQUIPMENT

Know your equipment's capabilities, dimensions and operations before operating. Visually inspect your equipment before you start, and never operate equipment that is not in proper working order with all safety devices intact. Check all hardware to assure it is tight. Make certain that all locking pins, latches, and connection devices are properly installed and secured. Remove and replace any damaged, fatigued or excessively worn parts. Make certain all safety decals are in place and are legible. Keep decals clean, and replace them if they become worn and hard to read.

WARNING!



PROTECT AGAINST FLYING DEBRIS

Always wear proper safety glasses, goggles or a face shield when driving pins in or out or when operation causes dust, flying debris, or any other hazardous material.

WARNING!



LOWER OR SUPPORT RAISED EQUIPMENT

Do not work under raised booms without supporting them. Do not use support material made of concrete blocks, logs, buckets, barrels or any other material that could suddenly collapse or shift positions. Make sure support material is solid, not decayed, warped, twisted, or tapered. Lower booms to ground level or onto blocks. Lower booms and attachments to the ground before leaving the cab or operator's station.

WARNING!



USE CARE WITH HYDRAULIC FLUID PRESSURE

Hydraulic fluid under pressure can penetrate the skin and cause serious injury or death. Hydraulic leaks under pressure may not be visible. Before connecting or disconnecting hydraulic hoses, read your prime movers operator's manual for detailed instructions on connecting and disconnecting hydraulic hoses or fittings.

- Keep unprotected body parts, such as face, eyes, and arms as far away as possible from a suspected leak. Flesh injected with hydraulic fluid may develop gangrene or other permanent disabilities.
- If injured by injected fluid, see a doctor at once. If your doctor is not familiar with this type of injury, ask him to research immediately to determine proper treatment.

GENERAL SAFETY PRECAUTIONS CONTINUED

- Wear safety glasses, protective clothing, and use a sound piece of cardboard or wood when searching for hydraulic leaks.

**DO NOT USE YOUR HANDS!
SEE ILLUSTRATION.**

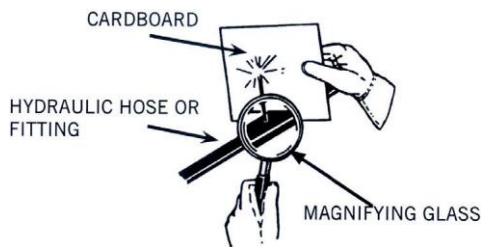

WARNING!



DO NOT MODIFY MACHINE OR ATTACHMENTS

Modifications may weaken the integrity of the attachment and may impair the function, safety, life and performance of the attachment. When making repairs, use only the manufacturer's genuine parts, following authorized instructions. Other parts may be substandard in fit and quality. Never modify any ROPS (Roll Over Protection System) equipment or device. Any modifications must be authorized in writing by the manufacturer.

WARNING!



SAFELY MAINTAIN AND REPAIR EQUIPMENT

- Do not wear loose clothing, or any accessories that can catch in moving parts. If you have long hair, cover or secure it so that it does not become entangled in the equipment.
- Work on a level surface in a well-lit area.
- Use properly grounded electrical outlets and tools.
- Use the correct tool for the job at hand. Make sure they are in good condition for the task required.

GENERAL SAFETY PRECAUTIONS CONTINUED

- Wear the protective clothing equipment specified by the tool manufacturer.

WARNING!



SAFELY OPERATE EQUIPMENT Do not operate equipment until you are completely trained by a qualified operator in how to use the controls, know its capabilities, dimensions, and all safety requirements. See your prime movers manual for these instructions.

- Keep all step plates, grab bars, pedals, and controls free of dirt, grease, debris, and oil.
- Never allow anyone to be around the equipment when it is operating.
- Do not allow riders on the attachment or the prime mover.
- Do not operate the equipment from anywhere other than the correct operators position.
- Never leave equipment unattended with the engine running or with this attachment in a raise position.
- Do not alter or remove any safety feature from the prime mover or this attachment.
- Know your work site safety rules as well as traffic rules and flow. When in doubt on any safety issue, contact your supervisor or safety coordinator for an explanation.

SAFETY SIGNS & LABELS

1.

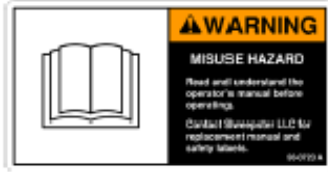

50-0723



50-0727



41043



50-0737



50-0724

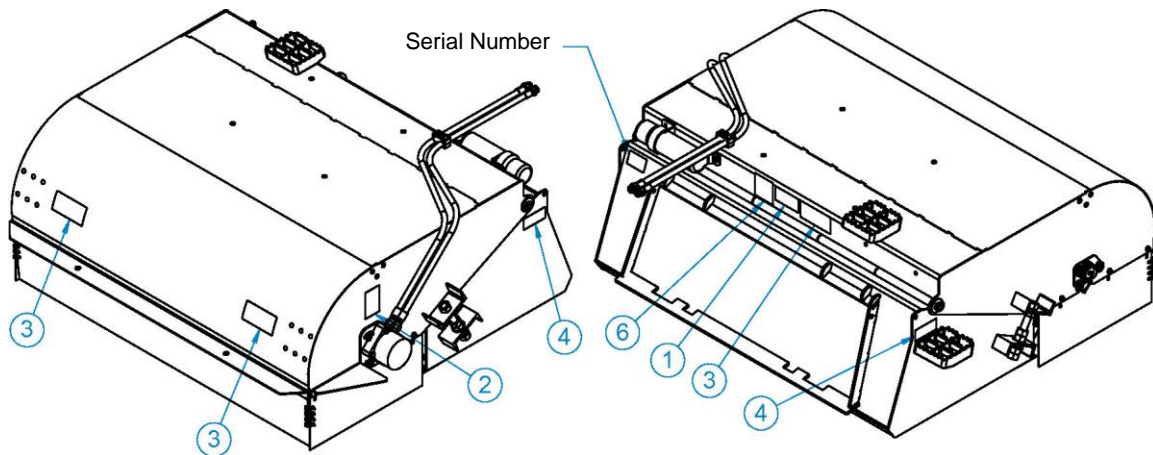

SAFETY SIGNS & LABELS

There are several specific signs on this sweeper. The exact location of the hazards and description of the hazards are reviewed.

Item	Part	Qty	Description
1.	50-0723	1	Label, Read Manual
2.	50-0724	1	Label, Warning, High Pressure
3.	50-0727	3	Label, Warning, Flying Objects
4.	50-0737	2	Label, Warning, Pinch Point
6.	41043	1	Decal, Warning, Hazardous

Placement or replacement of Safety Signs

2. Clean the area of application with nonflammable solvent, and then wash the same area with soap and water.

2. Allow the surface to fully dry.

3. Remove the backing from the safety sign, exposing the adhesive surface.

4. Apply the safety sign to the position shown in the diagram above and smooth out any bubbles.

Instructions

2. Replace all missing, illegible, or damaged safety signs.

3. Replacement parts, for parts with safety signs attached, must also have safety signs attached.

4. Safety signs are available, free of charge, from your dealer or from SPARTAN.

SERVICE & REPAIR - SAFETY

CAUTION!



DO NOT MODIFY THE SWEEPER IN ANY WAY. Personal injury could result. If you have questions, contact SPARTAN.

Repair or adjust the sweeper in a safe area, away from traffic and other hazards.

Before adjusting or servicing the sweeper, lower the sweeper to the ground, stop the prime mover engine, set the brakes and remove the key from the ignition.

When working on or around the sweeper, lower it to the ground or secure it with transport chains or cylinder-stop locks.

Stop the prime mover engine and cycle control levers to release hydraulic pressure before servicing or adjusting sweeper hydraulic systems.

WARNING!



ESCAPING HYDRAULIC FLUID CAN HAVE ENOUGH PRESSURE TO PENETRATE THE SKIN, causing serious personal injury.

Do not bend high pressure lines. Do not strike high pressure lines. Do not install bent lines, bent tubes, or kinked hoses. Do not install damaged lines, tubes, or hoses.

Repair damaged or loose lines, tubes and hoses. Leaks can cause fires. See your SPARTAN dealer for repair or replacement parts.

Replace the parts if any of the following conditions are present:

The end fittings are damaged or leaking.

The outer covering is chafed or cut.

The reinforcing wire layer is exposed.

The outer covering is ballooning locally.

The hose is kinked or crushed.

The hose has been pulled or stretched.

Make sure that all clamps, guards, and shields are installed correctly.

OPERATION

CAUTION!



A SWEEPER IS A DEMANDING MACHINE. Only fully trained operators or trainee operators under supervision of a fully trained person should use this machine.

Before operating sweeper:

- Learn sweeper and prime mover controls in an off-road location.
- Be sure that you are in a safe area, away from traffic or other hazards.
- Check all hardware holding the sweeper to the host machine, making sure it is tight.
- Replace any damaged or fatigued hardware with properly rated fasteners.
- Make sure all hydraulic hardware and hydraulic fittings are tight.
- Replace any damaged or fatigued fittings or hoses.
- Check all tire pressures before sweeping.
- Check tire ratings to be sure they match the prime mover load. Weigh the sweeper end of the prime mover, if necessary, to insure proper tire rating.
- Remove from the sweeping area all property that could be damaged by flying debris.
- Be sure all persons not operating the sweeper are clear of the sweeper discharge area.
- Always wear proper apparel such as a long sleeved shirt buttoned at the cuffs; safety glasses, goggles or a face shield; ear protection; and a dust mask.

While operating sweeper:

- When operating sweeper, adhere to all government rules, local laws and other professional guidelines for your sweeping application.

- Before leaving the operators area for any reason, lower the sweeper to the ground. Stop the prime mover engine, set the brakes and remove the key from the ignition.
- Minimize flying debris - use the slowest rotating speed that will do the job.
- Keep hands, feet, hair and other loose clothing away from all moving parts.
- Leave the brush hood (shield) and all other shields and safety equipment in place when operating the sweeper and primer mover.
- Be aware of extra weight and width a sweeper adds. Reduce travel speed accordingly.
- When sweeping on rough terrain, reduce speed to avoid "bouncing" the sweeper. Loss of steering can result.
- Never sweep toward people, buildings, vehicles or other objects that can be damaged by flying debris.
- Only operate the sweeper while you are in the seat of the prime mover. The seat belt must be fastened while you operate the prime mover. Only operate the controls while the engine is running. Protective glasses must be worn while you operate the prime mover and while you operate the sweeper.
- While you operate the sweeper slowly in an open area, check for proper operation of all controls and all protective devices. Note any repairs needed during operation of the sweeper. Report any needed repairs.

Before Each Use

Perform daily maintenance as indicated in Maintenance Schedule.

Run the prime mover and sweeper at a low idle. Check for hydraulic leaks or other problems and make corrections, if necessary, before using the sweeper.

WARNING!



AVOID SERIOUS INJURY. Check for large objects that could harm the operator or others if thrown by the sweeper. Remove these items before operating.

During Use

Carry the sweeper low to the ground so that the operator has good visibility and stability. Avoid any sudden movements from one side to the other side when you carry a sweeper.

Avoid excessive downward pressure on the brush sections to prevent excessive wear. A two to four inch wide pattern is sufficient for most applications. Ensure that the motor and bearing plates are equally adjusted in order to prevent an uneven wear pattern.

Directing Debris

Observe wind direction. Sweeping with the wind makes sweeping more effective and helps keep debris off the operator.

The terms *swing* and *angle* are used interchangeably.

NOTICE!

AVOID SWEEPER DAMAGE.
Reduce travel speed to avoid hitting immovable objects.

Brush, Engine & Travel Speeds

Vary brush, engine and travel speeds to match sweeping conditions.

Dirt & Gravel

To keep dust at a minimum, plan sweeping for days when it is overcast and humid or after it has rained. Also, sweep so the wind blows at your back.

Low brush speeds and moderate travel speeds work best for cleaning debris from hard surfaces. Brush speeds that are too fast tend to raise dust because of the aggressive sweeper action.

To sweep gravel, use just enough brush speed to "roll" the gravel, not throw it.

Heavy Debris

Travel slowly - 5 mph (8 kph).

Sweep a path less than the full width of the sweeper.

Increase engine speed if debris becomes very heavy.

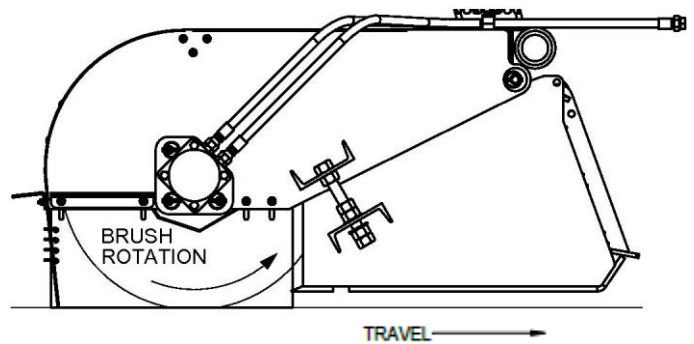
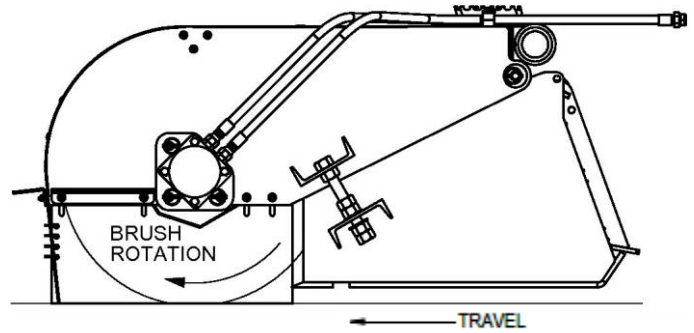

STORAGE

NOTICE! *Do not store the sweeper with weight on the brush. Weight will deform the bristles, destroying the sweeping effectiveness.*

Do not store polypropylene brushes in direct sunlight. The material can deteriorate and crumble before the bristles are worn out.

Keep polypropylene brush material away from intense heat or flame.

WARNING! **EXPOSURE TO RESPIRABLE CRYSTALLINE SILICA DUST ALONG WITH OTHER HAZARDOUS DUSTS MAY CAUSE SERIOUS OR FATAL RESPIRATORY DISEASE.** It is recommended to use dust suppression, dust collection and if necessary personal protective equipment during the operation of any attachment that may cause high levels of dust.

PRODUCT INFORMATION

Specifications

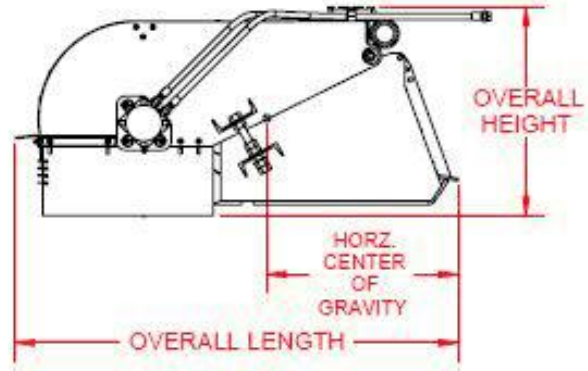
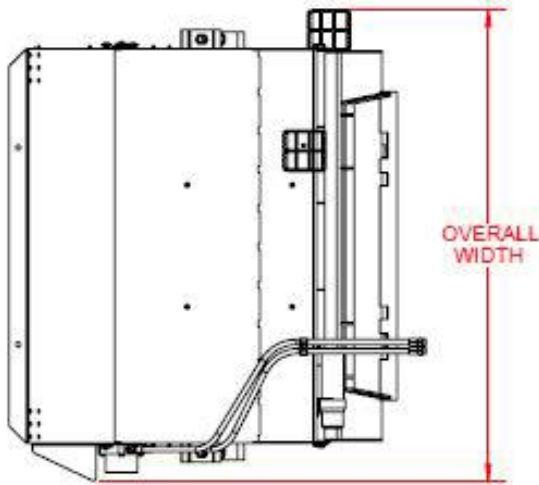

Overall Height	28.8 inches (all models)
Overall Width	74.4 inches 5 ft 86.4 inches 6 ft 98.4 inches 7 ft
Overall Length	61.0 inches (all models)
Sweeping Width	60.0 inches 5 ft 72.0 inches 6 ft 84.0 inches 7 ft
Center of Gravity	26.4 inches (all models)
Weight - Standard	840 lbs 5 ft 956 lbs 6 ft 1072 lbs 7 ft
Weight - Cold Planer Special (24 inch Pack)	892 lbs 5 ft 1008 lbs 6 ft 1124 lbs 7 ft
Flow Range	18.3 C.I. Motor 10-18 gpm 28.3 C.I. Motor 15-25 gpm
Maximum Pressure	3500 psi
Brush Diameter	26 inches

MAINTENANCE

Brush Pattern

A properly adjusted brush offers the best sweeper performance. To check the brush pattern:

1. Move the sweeper to a dusty, flat surface.
2. Set the prime movers parking brake and leave the engine running.
3. Start the sweeper rotating at a slow speed; then, lower it so the broom arms bottom out. Run the sweeper in the operating position (bottom of bucket about 1 inch off ground) for 10 seconds.
4. Raise the sweeper and back away, set parking brake, shut down the prime mover and remove the ignition key, exit the prime mover and inspect the brush pattern. The brush pattern left in the dust should be 2-4 inches wide, running the length of the brush. (figure 1)
5. Adjust the brush pattern as necessary according to the following instructions and recheck the brush pattern.

Adjusting Brush Pattern

1. Loosen the bottom 1 inch nut.
2. Adjust the top 1 inch nut to set the pattern. Tighten (clockwise) to increase pattern. Loosen (Counterclockwise) to decrease pattern.
3. When the pattern is set, tighten the bottom 1 inch nut.
4. Adjust the flaps so they just touch the ground.

NOTICE! To extend brush life make sure bolts on both sides are adjusted evenly.

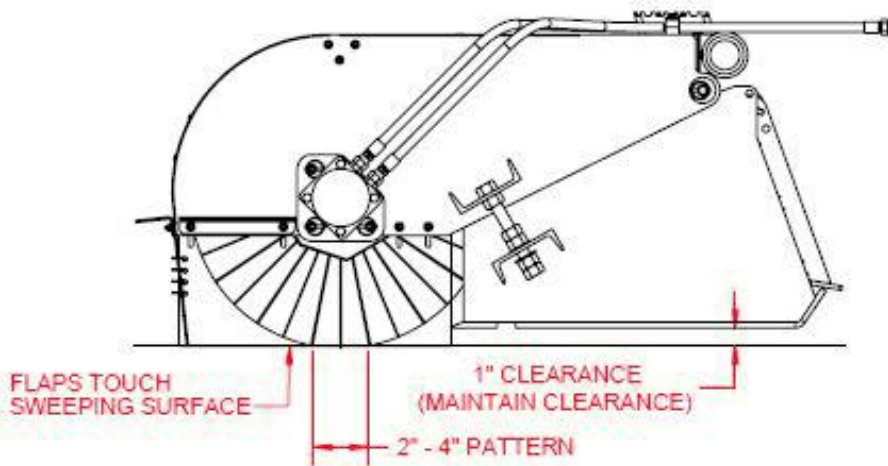

Worn Section Standard				Reference Information	
Section 00, New	Ring 10	Section 00, Worn	Exposed Bristle, Worn	Bristle Length	Exposed Bristle, New
24	6.38	17	3.8	8.50	7.5
26	8.00	18	4.0	9.00	8.0
32	10.00	22	5.0	11.00	10.0
36	10.00	24	6.0	13.00	12.0
36	10.63	25	6.0	12.69	11.4
46	19.38	34	6.0	13.31	12.1

REPLACING BRUSH SECTIONS

4.

1. Remove the side flaps. Retain hardware for reinstallation.
2. Remove motor mount lynch pins. Retain pins for reinstallation. Remove motor assembly. Do not tangle hoses.
3. Remove bearing mount lynch pins. Retain pins for reinstallation.
4. Lift sweeper body leaving core on ground.
5. Remove the bearing mounting plate and section retainer plate. Retain hardware for reinstallation.
6. Remove old sections.
7. Install new sections by doing the following:

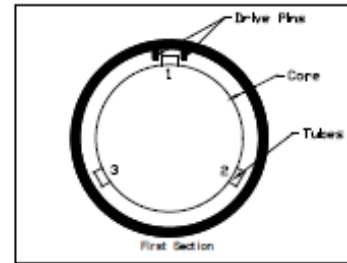

figure 1

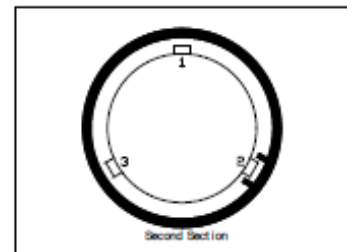

figure 2

- a. Number the tubes on the core as 1,2 and 3 (figure 1).
- b. Slide the first section onto the core with the drive pins on either side of square stock 1. Make sure that the drive pins angle up (figure 1).
- c. Place the second section on the core with the drive pins on either side of square stock 2. Be sure the drive pins angle down (figure 2).

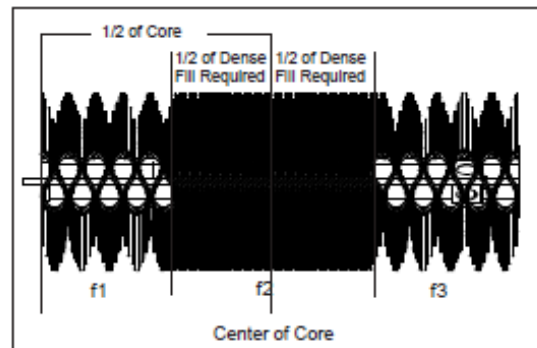

figure 3 (CP Special Only)

- d. Put the third section on with the drive pins around square stock 3. Be sure the drive pins angle up. (Proceed to step e or f.)
 - e. For SE Hopper, slide sections on until the core is full, making sure to alternate the square stock used and the direction of the drive pins. (Proceed to step 8.)
- f1. For CP Special, slide sections on as stated above up to a predetermined point which is 1/2 of the densely packed area below the center of the core. (figure 3)
 - f2. For CP Special, slide the next section on with the drive pins in the same up or down angle as the previous section but continue positioning the drive pins on either side of the next sequential square stock. Continue assembly in this manner until the densely

packed area is full. (figure 3)

- f3. For CP Special, revert back to alternating up and down angle for the drive pins until the core is full. (figure 3)
8. Re-attach the section retainer and bearing mounting plate with previously removed hardware.
9. Lay core on ground. Lower body over core.
10. Re-attach the bearing mounting plate with previously removed lynch pins.
11. Re-attach motor assembly with lynch pins.
12. Re-attach side flaps with hardware removed in first step.

MAINTENANCE SCHEDULE

Procedure	Before Each Use	After Each Use	100 Hours	500 Hours	See Prime Mover Manual
Brush pattern - Check (See Pattern Adjustment)	✓				
Fittings/hoses, hydraulic - Check for Leaks - Check for damage	✓				
Fittings, zerk - Grease (See Lubrication Points)	✓				
Oil, hydraulic (Prime Mover)- Check Level - Check Cleanliness	✓	See Below for Requirements			
Hardware -Check for tightness	✓				

Oil Cleanliness Requirements

NOTICE! *All hydraulic fluid shall be filtered before use in any SPARTAN product to obtain the cleanliness standard of ISO 4406:20118113, unless explicitly specified otherwise.*

Repair loose lines, tubes and hoses. Repair damaged lines, tubes and hoses. Leaks can cause fires. See your Spartan dealer for repair or replacement parts. Check lines, tubes and hoses carefully. Do not use your hand to check for leaks. Use a board or cardboard to check for leaks. Tighten all connections to the recommended torque.

Fittings/Hoses Inspection Guideline

Stop the prime mover engine and release hydraulic pressure before servicing or adjusting sweeper hydraulic systems.

WARNING! **ESCAPING HYDRAULIC FLUID CAN HAVE ENOUGH PRESSURE TO PENETRATE THE SKIN**, causing serious personal injury.



Do not bend or strike high pressure lines. Do not install bent or kinked lines, hoses or tubes. Do not install damaged lines, tubes or hoses.

Replace the parts if any of the following conditions are present:

- The end fittings are damaged or leaking.
- The outer covering is chafed or cut.
- The reinforcing wire layer is exposed.
- The outer covering is ballooning locally.
- The hose is kinked or crushed.
- The hoses have been pulled or stretched.

Make sure that all clamps, guards and shields are installed correctly.

TROUBLESHOOTING

Brush Head Assembly

Problem	Possible Cause	Possible Solution
Motor for broom will not operate	Auxiliary hydraulics control on prime mover is activated in the wrong position	Verify controls. See prime mover owner's manual
	Hoses improperly connected to prime mover	Connect hoses correctly to prime mover
	Hoses on prime mover are obstructed	Clear obstruction on prime mover
	Hoses on broom are obstructed	Clear obstruction on broom
	The motor has failed	Replace the motor
Sluggish broom operation	Insufficient oil flow from the prime mover	Increase engine RPM
	One or more seals have failed in the motor	Replace the seals or motor
	Hydraulic filter on prime mover is dirty	Replace filter
The motor runs but the broom does not run	Motor shaft has a sheared key	Replace key
Oil leaks from the motor	One or more seals have failed in the motor	Replace the seals or motor
	Seals on the fittings are damaged	Replace seals or fittings
	Fittings are loose or damaged	Tighten or replace fittings
	Hydraulic hoses are loose or damaged	Tighten or replace hoses
Brush rotates in wrong directions	Hoses installed incorrectly	Switch hose connections
Brush slows or stops when sweeping	Brush pattern too wide	Adjust brush pattern, see page 12
	Travel speed too fast	Reduce travel speed
	Trying to sweep too much material at once.	Reduce amount of material being swept, make more passes
	Hydraulic motor is failing	Replace motor
Brush wears very quickly	Brush pattern is too wide	Adjust brush pattern, see page 12

TROUBLESHOOTING

Hydraulic Assembly

Problem	Possible Cause	Possible Solution
Excessive hydraulic oil temperature	Low hydraulic oil level on the prime mover	Add hydraulic fluid
	Hydraulic hoses are obstructed	Clear obstructions in hoses
	Hydraulic oil and/or filter on prime mover are dirty	Replace hydraulic oil and/or filter on prime mover
	Quick couplers are not properly seated	Reconnect quick couplers properly
	Brush pattern too wide	Adjust brush pattern, see page 12
	Travel speed too fast	Reduce travel speed
	Trying to sweep too much material at once	Reduce the amount of material being swept. Make more passes.
	Hydraulic motor is failing	Replace motor
Hydraulic quick coupler leaks	Quick coupler poppet is unseated or damaged	Reconnect or replace the quick couplers

ADJUSTING THE GUTTERBROOM

Adjusting Gutterbroom Pattern

When the gutterbroom height is properly adjusted, bristles contact the ground as shown in figure 1.

To adjust the gutterbroom:

1. Lower the gutterbroom to the ground.
2. Loosen the hardware holding the gutterbroom motor mounting plate.
3. Turn the motor mounting plate to the right or left.
4. Adjust the tension chain so it holds the gutterbroom in place.
5. Tighten the hardware holding the motor mounting plate.

Adjusting Gutterbroom Swing

A properly adjusted gutterbroom extends the main brush's sweeping path, leaving no streaks between the two paths. For this to happen, the inside edge of the gutterbroom brush pattern must line up with the outside edge of the sweeper.

To adjust gutterbroom swing:

1. Loosen the nut.
2. Adjust the screw. Turn it in for more swing or turn it out for less swing.
3. Tighten the nut.

Using Gutterbroom

The gutterbroom is for sweeping forward only.

When sweeping next to curbs or walls with a gutterbroom, only the bristle tips should touch the vertical surface.

When not using the gutterbroom for a short period, raise it 1-2 inches (25-51 mm) off the ground with the tension chain. During extended periods of no use, unhook hydraulic hoses from the gutterbroom motor, remove the gutterbroom assembly and connect hydraulic hoses to run only the main brush.

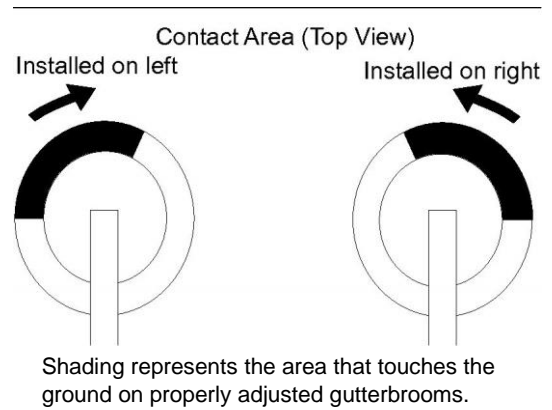

figure 1

WARNING! ESCAPING HYDRAULIC FLUID CAN HAVE ENOUGH PRESSURE TO PENETRATE THE SKIN, causing serious personal injury.



Replacing Gutter Brush

1. Remove the worn gutter brush section from the brush plate.
2. Mount a new gutter brush section to the brush plate reusing the hardware.
3. Adjust according to "Adjust Gutterbroom Pattern" and "Adjusting Gutterbroom Swing".

Notes

5.

CORE ASSEMBLY

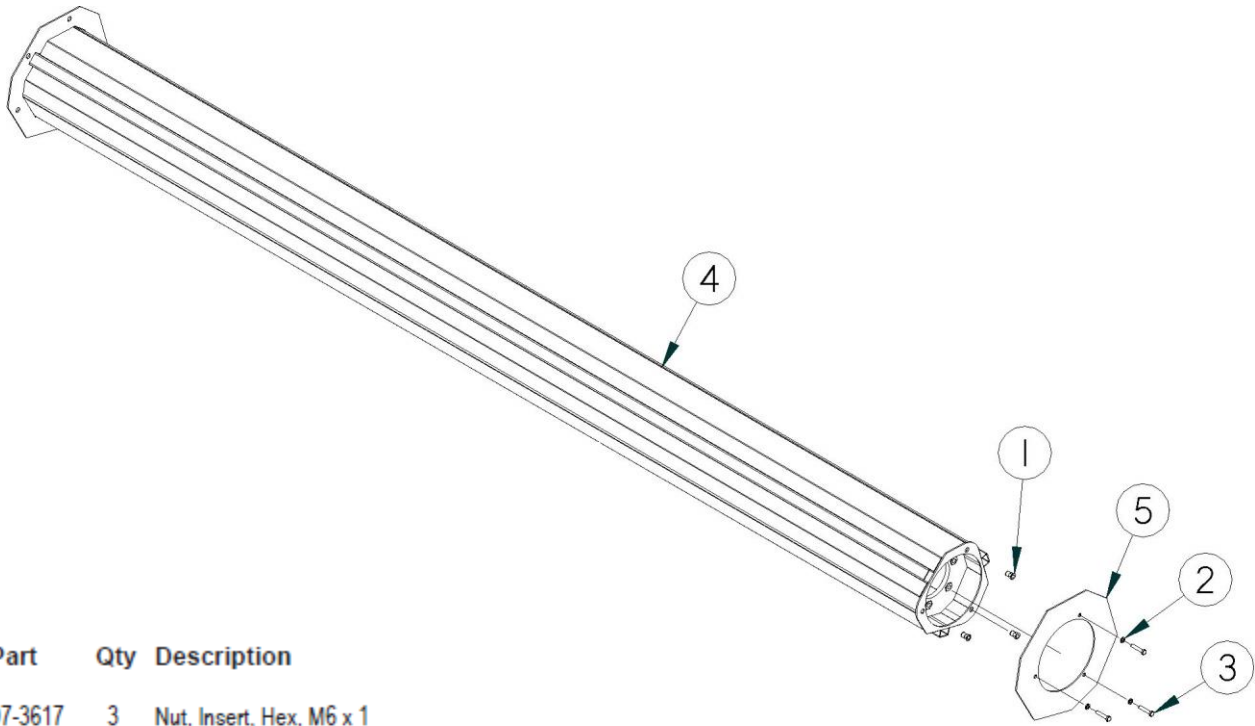

Item	Part	Qty	Description
1.	07-3617	3	Nut, Insert, Hex, M6 x 1
2.	07-3730	3	Washer, Lock, Split, Medium, M6
3.	07-3731	3	Screw, HHC, CL10.9, M6-1 x 30MM
4.	13-15657-5	1	Weld, Core, 8, 5 Ft
	13-15657-6	1	Weld, Core, 8, 6 Ft
	13-15657-7	1	Weld, Core, 8, 7 Ft
5.	13-15662	1	Plate, Section, Retainer, 8

Not Shown:

01-0851	1	Set, Section, Poly, 5 ft
01-0853	1	Set, Section, Poly, 6 ft
01-9279	1	Set, Section, Poly, 7 ft
01-1156	1	Set, Section, Mixed, 5 ft
01-1168	1	Set, Section, Mixed, 6 ft
01-1169	1	Set, Section, Mixed, 7 ft
01-5010	Varies	Section, 26, 8, Mixed, Convoluted, Heavy Fill

**Cold Planer Special Only
Brush Quantity Chart**

	Nominal 5 ft	Nominal 6 ft	Nominal 7 ft
Nested Width	Total Quantity	Total Quantity	Total Quantity
12	44	51	57
16	48	54	61
20	51	58	64
24	54	61	68
30	59	66	73
36	64	71	78
40	68	74	81
48	74	81	88
Full	82	98	115

MOTOR ASSEMBLY

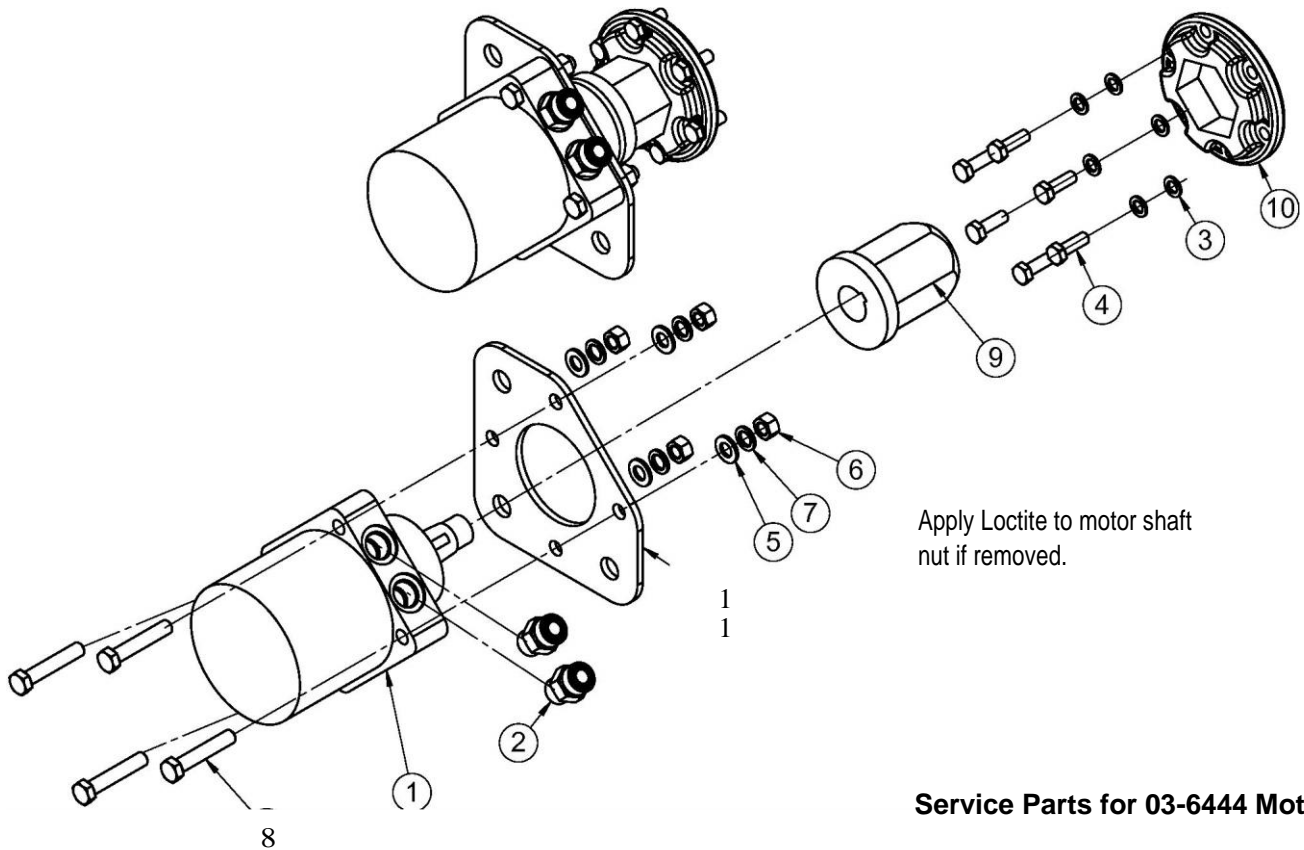

Service Parts for 03-6444 Motor

- 07-8215 Motor, Shaft, Lock, Nut
- 03-6468 Seal Kit
- 07-7529 Replacement Key

Service Parts for 03-6335 Motor

- 07-8215 Motor, Shaft, Lock, Nut
- 03-6468 Seal Kit
- 07-7529 Replacement Key

Service Parts for 03-5612 Motor

- 07-4568 Motor, Shaft, Lock, Nut
- 03-5503 Seal Kit
- 07-7286 Replacement Key

Service Parts for 03-5613 Motor

- 07-4568 Motor, Shaft, Lock, Nut
- 03-5644 Seal Kit
- 07-7286 Replacement Key

Item	Part	Qty	Description
1.	03-6444	1	Motor, 17.1 CID, 1.25 TPR (Serial #1231001 & Up)
	03-6335	1	Motor, 24.7 CID, 1.25 TPR (Serial #1231001 & Up)
	03-5612	1	Motor, 18.3 CID, 1.25, TPR (Serial # 1230199 & Down)
	03-5613	1	Motor, 28.3 CID, 1.25, TPR (Serial # 1230199 & Down)
2.	03-5901	2	Fitting, 10MB-10MF
3.	07-3747	6	Washer, Lock, Split, Medium, M10
4.	07-3749	6	Screw, HHC, CL 10.9, M10-1.50 x 30MM
5.	07-3754	4	Washer, Flat, CL 10.9, M12
6.	07-3755	4	Nut, Hex, CL 10.9, M12-1.75
7.	07-3756	4	Washer, Lock, Split, Medium, M12
8.	07-6683	4	Screw, HHC, CL 10.9, M12-1.75 x 65MM
9.	13-15206	1	Hub, Hex, 21/2 x 11/4, Tapered Bore x 3.75
10.	13-16225	1	Plate, Receiver, Hex, 2.50 Inch
11.	13-17039	1	Plate, Mounting, Motor, Toolless

BEARING ASSEMBLY

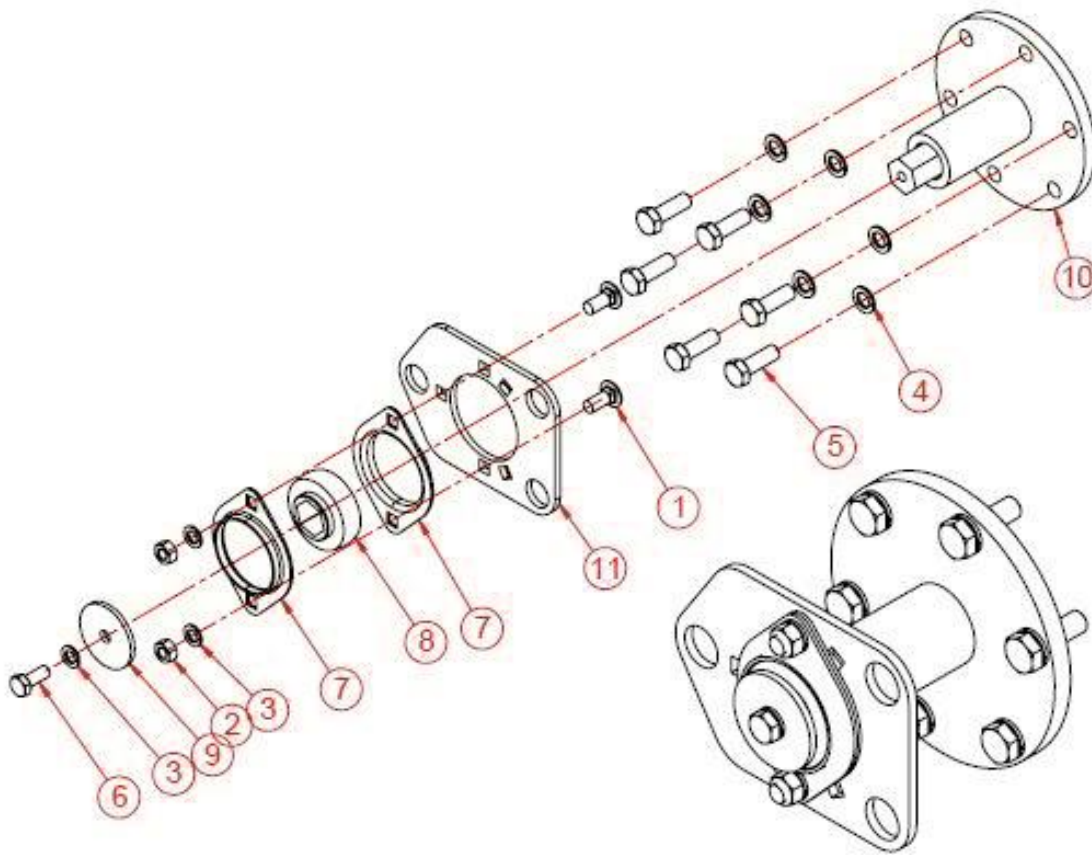

Item	Part	Qty	Description
1.	07-2950	2	Bolt, Carriage, CL8.8, M8-1.25 x 20mm
2.	07-3737	2	Nut, Hex, CL1 0, M8-1.25
3.	07-3738	3	Washer, Lock, Split, Medium, M8
4.	07-3747	6	Washer, Lock, Split, Medium, M10
5.	07-3749	6	Screw, HHC, CL 10.9, M10-1.5 x 30mm
6.	07-3777	1	Screw, HHC, CL 10.9, M8-1.25 x 20
7.	08-0005	2	Flange, Bearing, 2 Hole
8.	08-0037	1	Bearing, 7/8 Hex, without Hub
9.	13-11903	1	Washer, .34 x 1.8 x 10ga
10.	13-16923	1	Weld, Hex, Shaft, Idler, Bolt-In
11.	13-17015	1	Plate, Mounting, Bearing, Toolless

BEARING ASSEMBLY COLD PLANER

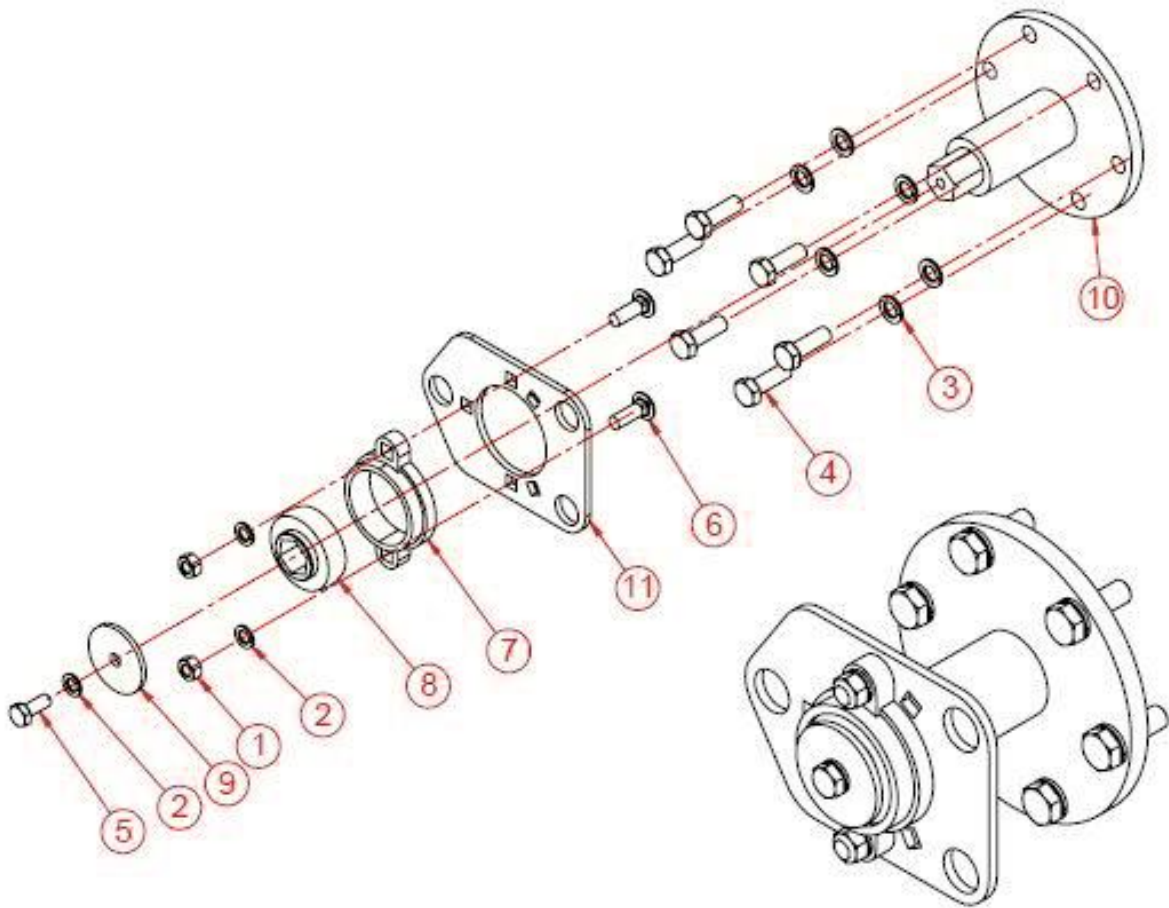

Item	Part	Qty	Description
1.	07-3737	2	Nut, Hex, CL1 0, M8-1.25
2.	07-3738	3	Washer, Lock, Split, Medium, M8
3.	07-3747	6	Washer, Lock, Split, Medium, M10
4.	07-3749	6	Screw, HHC, CL 10.9, M10-1.5 x 30mm
5.	07-3777	1	Screw, HHC, CL 10.9, M8-1.25 x 20
6.	07-5933	2	Bolt, Carriage, CL8.8, M8-1.25 x 25mm
7.	08-0029B	1	Flange, Bearing, 2 Hole
8.	08-0037	1	Bearing, 7/8 Hex, without Hub
9.	13-11903	1	Washer, .34 x 1.8 x 10ga
10.	13-16923	1	Weld, Hex, Shaft, Idler, Bolt-In
11.	13-17015	1	Plate, Mounting, Bearing, Toolless

HOOD ASSEMBLY

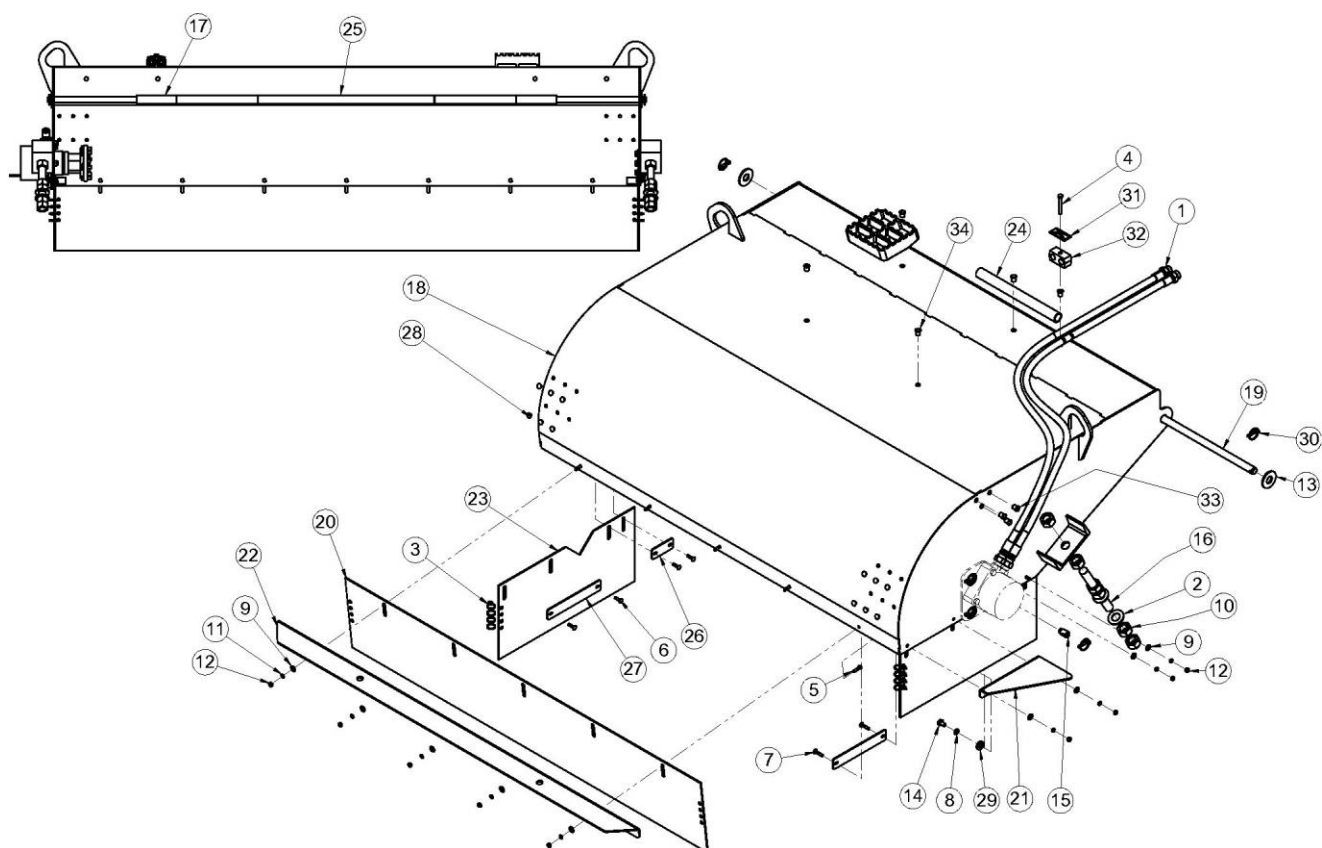

Item	Part	Qty	Description	Item	Part	Qty	Description
1.	03-5653	2	Hose, .50 x 120, 10FF, 12MB, 3500psi	18.	13-17035-5	1	Weld, Body (5 ft)
2.	07-0159	4	Washer, Flat, Gr2, 1	13-17035-6	1	Weld, Body (6 ft)	
3.	07-1767	8	Tie, Plastic, 15 1/2, Black	13-17035-7	1	Weld, Body (7 ft)	
4.	07-1784	1	Screw, HHC, Gr8, 5/16-18 x 2 1/2	19.	13-17038-5	1	Rod, 7/8 x 63.5 (5 ft)
5.	07-3637	5	Screw, HHC, Gr8, 1/4-20 x 1 (5 ft)	13-17038-6	1	Rod, 7/8 x 75.5 (6 ft)	
	07-3637	6	Screw, HHC, Gr8, 1/4-20 x 1 (6 ft)	13-17038-7	1	Rod, 7/8 x 87.5 (7 ft)	
	07-3637	7	Screw, HHC, Gr8, 1/4-20 x 1 (7 ft)	20.	13-17042-5	1	Flap, Front (5 ft)
6.	07-3691	6	Bolt, Carriage, Gr5, 1/4-20 x 1	13-17042-6	1	Flap, Front (6 ft)	
7.	07-3692	2	Bolt, Carriage, Gr5, 1/4-20 X 1 1/4	13-17042-7	1	Flap, Front (7 ft)	
8.	07-3747	6	Washer, Lock, Split, Medium, M10	21.	13-17046	1	Plate, Guard, Motor
9.	07-4032	13	Washer, Flat, Gr8, 1/4 (5 ft)	22.	13-17047-5	1	Plate, Guard, Front (5 ft)
	07-4032	14	Washer, Flat, Gr8, 1/4 (6 ft)	13-17047-6	1	Plate, Guard, Front (6 ft)	
	07-4032	15	Washer, Flat, Gr8, 1/4 (7 ft)	13-17047-7	1	Plate, Guard, Front (7 ft)	
10.	07-4035	12	Nut, Hex, Gr8, 1-8	23.	13-17059	2	Flap, Side
11.	07-4038	13	Washer, Lock, Split, Medium, 1/4,(5 ft)	24.	13-17072	1	Tube, Round, 1 x 13.63, (5 ft 6 ft)
	07-4038	14	Washer, Lock, Split, Medium, 1/4,(6 ft)	25.	13-17073	1	Tube, Round, 1 x 25.75 (7 ft)
	07-4038	15	Washer, Lock, Split, Medium, 1/4,(7 ft)	26.	LAF8330	2	Plate, Side, Flap, Retainer, Short
12.	07-4039	13	Nut, Hex, Gr8, 1/4 (5 ft)	27.	LAF8331	2	Plate, Side, Flap, Retainer, Long
	07-4039	14	Nut, Hex, Gr8, 1/4 (6 ft)	28.	LAF9853	12	Plug, .375, Plastic, Black
	07-4039	15	Nut, Hex, Gr8, 1/4 (7 ft)	29.	P852608	6	Washer, Hard, 1/2
13.	07-5451	2	Washer, Flat, Gr8, 7/8	30.	RHW8068	8	Pin, Lynch, 1/4
14.	07-6769	6	Screw, HHC, CL10.9, M10-1.5 x 16mm	31.	RHW8614	1	Cover, Plate
15.	13-14083	6	Stud, Mounting, Motor	32.	RHW8616	1	Hose, Cradle
16.	13-16240	2	Rod, Threaded, 1-8 x 9	33.	RHW8642	9	Nut, Rivet, 5/16-18, .15-.312 Grip
17.	13-16308	2	Tube, Round, 1 x 5.88, 6 ft (7 ft)	34.	RHW8645	2	Nut, Rivet, 5/16-18, .027-.15 Grip

CUTTING EDGE KIT

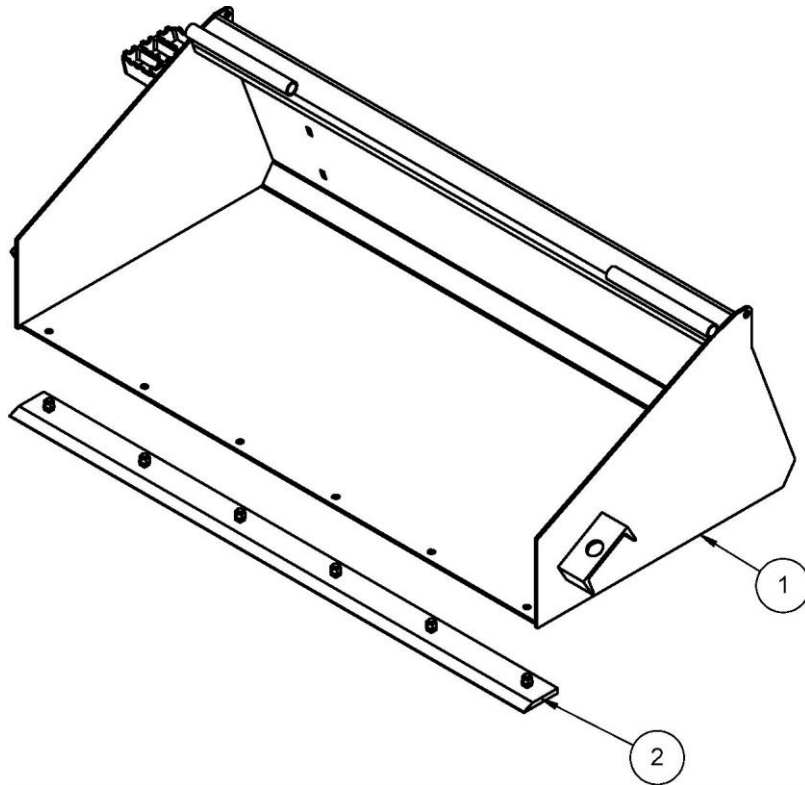

Item	Part	Qty	Description
------	------	-----	-------------

- | | | | |
|----|------------|---|---|
| 1. | | | Contact Spartan for your specific mounting. |
| 2. | 28-10370-5 | 1 | Kit, Cut, Edge, 5 ft |
| | 28-10370-6 | 1 | Kit, Cut, Edge, 6 ft |
| | 28-10370-7 | 1 | Kit, Cut, Edge, 7 ft |

GUTTERBROOM

Assembly 28-10323

Item	Part	Qty	Description	
1.	01-0523	1	Brush, Wire	
	01-0704	1	Brush, Poly	
2.	03-3481	2	Fitting, 10MB-8MF	
3.	03-4440	1	Hose, .5 x 126, 8FF-8FF, 3K, TC	
4.	03-4624	1	Fitting, 8MF-10FF	
5.	03-5377	1	Hose, .5 x 150, 8FF-8FF, 3K, AR	
6.	03-6443	1	Motor, 24 CID, (Serial # 1234001 & Up)	
	03-5611	1	Motor, 24.6 CID (Serial # 1233199 & Down)	
7.	03-5645	1	Fitting, 8MF-10MF	
8.	07-0018	4	Screw, HHC, Gr8, 3/8-16 x 1	
9.	07-0204	1	Pin, Roll, .25 x 2	
10.	07-0387	1	Chain, 3/16 (26 Links)	
11.	07-1125	1	Screw, HHC, Gr5, 1/2-13 x 2 1/2, Fully Threaded	
12.	07-1698	4	Screw, HHC, Gr8, 5/16-18 x 2	
13.	07-1714	7	Screw, HHC, Gr8, 5/16-18 x 1	
14.	07-1717	2	Bolt, Carriage, Gr5, 3/8-16 x 1 1/4	
15.	07-1718	6	Washer, Lock, Gr5, 3/8	
16.	07-1764	2	Nut, Hex, Gr8, 1/2-13	
17.	07-1784	1	Screw, Hex, Cap, Gr8, 5/16-18 x 2 1/2	
18.	07-1810	4	Nut, Hex, Lock, 5/16-18, Gr8	
19.	07-1973	6	Screw, HHC, Gr5, 5/16-18 x 1 1/4	
20.	07-3112	1	Zerk, Grease, 1/4-28, Self-Tapping	
21.	07-3273	13	Washer, Lock, Gr5, 5/16	
22.	07-3275	17	Washer, Flat, Gr8, 5/16	<u>Replacement Part for 03-6443 :</u>
23.	07-3279	2	Washer, Flat, Gr8, 3/8	
24.	07-3654	2	Nut, Hex, Gr8, 3/8-16	03-5799 Seal Kit
25.	07-4961	1	Pin, Cotter, Gr2, 1/8 x 2	07-1948 Replacement Key
26.	07-5054	1	Link, Quick, 3/16	
27.	07-6358	1	Pin, Clevis, 3/4 x 3 1/2	
28.	09-0156	2	Flange, Bearing, Nylon	
29.	13-0374	1	Plate, Mounting	<u>Replacement Part for 03-5611 :</u>
30.	13-12291	1	Washer, Flat, 2.375 x 1.625 x .134	
31.	13-2264	1	Arm	03-5643 Seal Kit
32.	13-2265	1	Plate, Motor, Mounting	07-7719 Replacement Key
33.	13-50075	2	Plate, Adjustment	
34.	13-50076	1	Plate, Mounting	
35.	13-50088	1	Plate, Attachment	
36.	13-50093	1	Pin, Pivot, Gutterbroom	
37.	13-50096	1	Pivot, Weldment	
38.	RHW8614	1	Plate, Cover, Hose Clamp Cradle	
39.	RHW8616	1pr	Hose, Cradle, 7/8 Hoses	
40.	RHW8642	6	Nut, Rivet, 5/16-18, .15-.312 Grip	

GUTTERBROOM

Assembly 28-10323

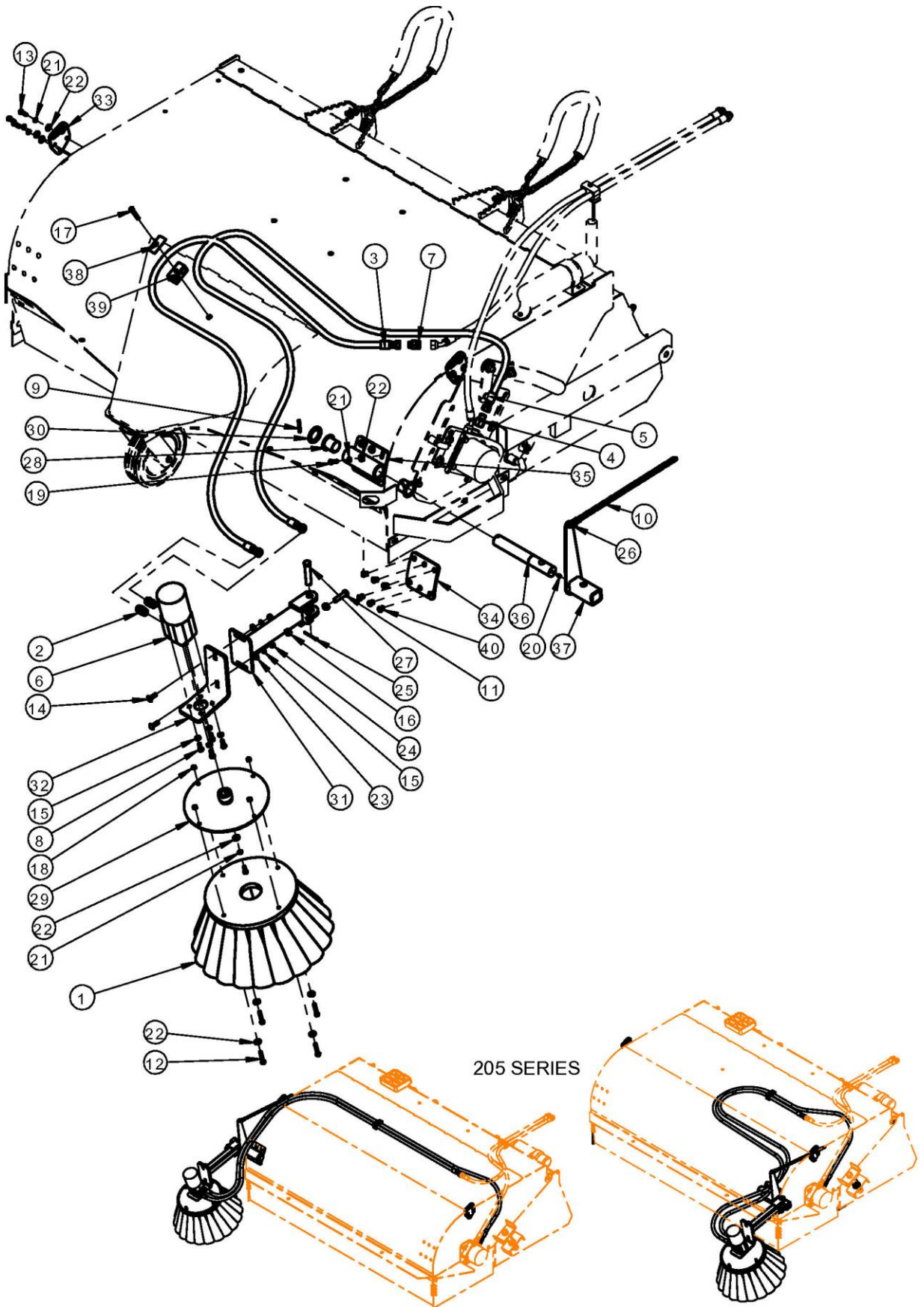

DUST SUPPRESSION KIT

Assembly 28-9139 12 Volt

Assembly 28-9193 24 Volt

Item Part	Qty	Description
1. 03-0076	1	Fitting, Nipple, BP, Close, 3/8
2. 03-0152	1	Fitting, Nipple, BP, Close, 1/2
3. 03-0457	1	Fitting, Barb, Nylon, 3/8, 3/8MP
4. 03-0819	1	Fitting, Reducerbushing, HP, 1/2,3/8
5. 03-1226	2	Fitting, Barb, HP, 5/8, 1/2MP
6. 03-1326	1	Pump, Water, 2.1 gpm, 12 Volt, 7 amp, 35psi
03-2558	1	Pump, Water, 2.1 gpm, 24 Volt, 3.5amp, 60psi
7. 03-1392	1	Valve, Shut-Off
8. 03-3537	3	a-Ring, #8 Face Seal
9. 07-0140	4	Washer, Lock, Gr2, #10
10. 07-0413	3	Nozzle, Cap, Nylon
11. 07-0414	3	Nozzle, Tip, Brass, 1.5
12. 07-0532	1	Strainer, Water
13. 07-0547	2	Clamp, Spring, 7/8 Hose
14. 07-0549	10	Clamp, Spring, 5/8 Hose
15. 07-1430	4	Washer, Flat, #10
16. 07-1973	4	Screw, HHC, Gr8, 5/16-18 x 1 1/4
17. 07-3150	1	Assembly, Tank, Water, 25 Gallon
18. 07-3273	4	Washer, Lock, Split, Medium, 5/16
19. 07-3275	4	Washer, Flat, Gr8, 5/16
20. 07-3869	4	Fitting, Barb, Tee, Nylon, 3/8
21. 07-4831	2	Screw, BHC, 1 0-24UNC, 2B x 3/4
22. 07-4862	4	Nozzle, Elbow, without Clamp
23. 07-5127	3	Hose, Clear, Vinyl, 3/8
24. 09-0028	25ft	Hose, Heater, 5/8
25. LAF2826	5ft	Bracket, Nozzle
26. LAF8316	1	Wire Harness, with Box
27. LAF8320	1	Wire Assembly x 11 ft
28. LAF8376	1	Sprinkler, Tank Mount
29. RHW2135	4	Screw, Socket Head, Flat, Gr5, 5/16-18 x 3/4

Replacement Parts for 03-1326 and 03-2558 :

07-6565 Fan Shroud
07-6566 Grommet Set (Qty 4)
07-6567 Mounting Kit

Replacement Part for 07-3150 :

07-3417 Cap

Replacement Parts for LAF8316 :

07-4942 Switch
07-1824 Rubber Boot
07-3152 Circuit Breaker

DUST SUPPRESSION KIT

Assembly 28-9139 12 Volt

Assembly 28-9193 24 Volt

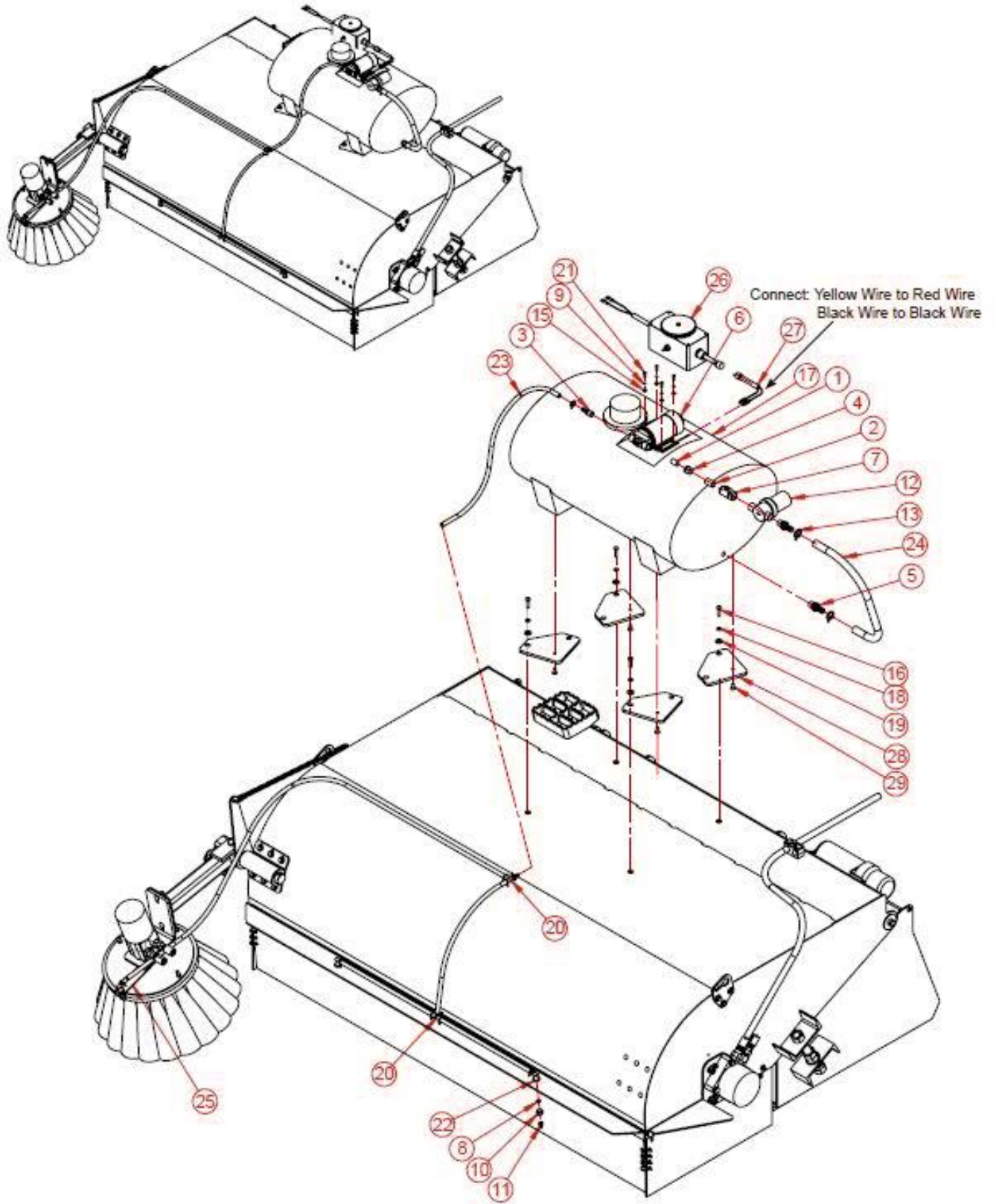



BOLT TORQUE SPECIFICATIONS

GENERAL TORQUE SPECIFICATION TABLES

Use the following charts when determining bolt torque specifications, when special torques are not given. Always use grade 5 or better when replacing bolts.



SAE BOLT TORQUE SPECIFICATIONS

Note: The following torque values are for use with extreme pressure lubricants, plating or hard washer applications. Increase torque 15 when using hardware that is unplated and either dry or lubricated with engine oil.

Bolt Size		SAE GRADE 5 TORQUE				SAE GRADE 8 TORQUE				Bolt head identification marks as per grade. NOTE: Manufacturing Marks Will Vary
Inches	mm	Ft-lbs		Newton-Meter		Ft-lbs		Newton-Meter		
1/4	6,35	8	9	11	12	10	13	14	18	<p>Grade 2</p>  <p>Grade 5</p>  <p>Grade 8</p> 
5/16	7,94	14	17	19	23	20	25	27	34	
3/8	9,53	30	36	41	49	38	46	52	62	
7/16	11,11	46	54	62	73	60	71	81	96	
1/2	12,70	68	82	92	111	94	112	127	152	
9/16	14,29	94	112	127	152	136	163	184	221	
5/8	15,88	128	153	174	207	187	224	254	304	
3/4	19,05	230	275	312	373	323	395	438	536	
7/8	22,23	340	408	461	553	510	612	691	830	
1	25,40	493	592	668	803	765	918	1037	1245	
1-1/8	25,58	680	748	922	1014	1088	1224	1475	1660	
1-1/4	31,75	952	1054	1291	1429	1547	1700	2097	2305	
1-3/8	34,93	1241	1428	1683	1936	2023	2312	2743	3135	
1-1/2	38,10	1649	1870	2236	2535	2686	3026	3642	4103	

METRIC BOLT TORQUE SPECIFICATIONS

NOTE: The following torque values are for use with metric hardware that is unplated and either dry or lubricated with engine oil. Reduce torque 15% when using hardware that has extreme pressure lubricants, plating or hard washer applications.

Bolt head identification marks as per grade.		
		

Bolt Size	Grade No.	Pitch (mm)	Ft-lbs	Newton-Meter	Pitch (mm)	Ft-lbs	Newton-Meter
M6	5.6		3,6-5,8	4,9-7,9		-	-
	8.8	1,0	5,8-4	7,9-12,7	-	-	-
	10.9		7,2-10	9,8-13,6		-	-
M8	5.6		7,2-14	9,8-19		12-17	16,3-23
	8.8	1,25	17-22	23-29,8	1,0	19-27	25,7-36,6
	10.9		20-26	27,1-35,2		22-31	29,8-42
M10	5.6		20-25	27,1-33,9		20-29	27,1-39,3
	8.8	1,5	34-40	46,1-54,2	1,25	35-47	47,4-63,7
	10.9		38-46	51,5-62,3		40-52	54,2-70,5
M12	5.6		28-34	37,9-46,1		31-41	42-55,6
	8.8	1,75	51-59	69,1-79,9	1,25	56-68	75,9-92,1
	10.9		57-66	77,2-89,4		62-75	84-101,6
M14	5.6		49-56	66,4-75,9		52-64	70,5-86,7
	8.8	2,0	81-93	109,8-126	1,5	90-106	122-143,6
	10.9		96-109	130,1-147,7		107-124	145-168
M16	5.6		67-77	90,8-104,3		69-83	93,5-112,5
	8.8	2,0	116-130	157,2-176,2	1,5	120-138	162,6-187
	10.9		129-145	174,8-196,5		140-158	189,7-214,1
M18	5.6		88-100	119,2-136		100-117	136-158,5
	8.8	2,0	150-168	203,3-227,6	1,5	177-199	239,8-269,6
	10.9		175-194	237,1-262,9		202-231	273,7-313
M20	5.6		108-130	146,3-176,2		132-150	178,9-203,3
	8.8	2,5	186-205	252-277,8	1,5	206-242	279,1-327,9
	10.9		213-249	288,6-337,4		246-289	333,3-391,6

HYDRAULIC TORQUE SPECIFICATIONS

Face Seal: Assembly. Tube to Fitting

NOTICE! *Face seal fittings have the most reliable sealing method and therefore, should be used whenever possible.*

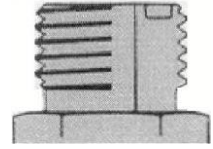

Installation

1. Make sure threads and sealing surfaces are free of burrs, nicks, scratches, or foreign materials.
2. Install proper SAE O-ring to end of fitting if not already installed. Ensure O-ring is fully seated and retained properly.
3. Lubricate O-ring with a light coating of clean hydraulic oil.
4. Position tube and nut squarely on face seal of fitting and tighten nut finger tight.
5. Using appropriate torquing device, tighten to given torque rating from the table below.

Torque Values

SAE Dash Size	Tube Side Thread Size	In-lbs	Ft-lbs
-4	9/16 -18	220 ± 10	18 ± 1
-6	11/16-16	320 ± 25	27 ± 2
-8	13/16-16	480 ± 25	40 ± 2
-10	1 - 14	750 ± 35	63 ± 3
-12	1 3/16 - 12	1080 ± 45	90 ± 4
-16	1 7/16 - 12	1440 ± 90	120 ± 8
-20	1 11/16-12	1680 ± 90	140 ± 8
-24	2 - 12	1980 ± 100	165 ± 8

NOTE - ft-lb may be converted to Newton Meters by multiplying by 1.35582.

NOTE - in-lbs may be converted to Newton Meters by multiplying by 0.11298.

HYDRAULIC TORQUE SPECIFICATIONS

7.

Straight Thread a-ring Fitting: Assembly. Fitting to Port

NOTE - Straight thread o-ring fittings are utilized to adapt hydraulic systems to motors, pumps, cylinders, and valves.

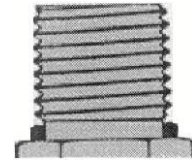

Installation (Adjustable Fitting)

1. Make sure threads and sealing surfaces are free of burrs, nicks, scratches, or any foreign materials.
2. Install proper SAE o-ring on port end of fitting if not already installed. Ensure o-ring is fully seated and retained properly.
3. Lubricate o-ring with a light coating of clean hydraulic oil.
4. Back off nut as far as possible and push washer up as far as possible. (figure 4 & 5)
5. Screw fitting into port. Hand tighten fitting until backup washer contacts face of port. (figure 6)
6. To position the fitting, unscrew to desired position, but not more than one full turn.
7. Hold fitting in position with wrench. Using appropriate torquing device, tighten nut to given torque rating from table. (figure 7)

Fitting Size	SAE Port Thread Size	In-lbs	Ft-lbs
-4	7/16-20	190 ± 10	16 ± 1
-6	9/16 - 18	420 ± 15	35 ± 1
-8	3/4 - 14	720 ± 25	60 ± 2
-10	7/8 - 14	1260 ± 50	105 ± 5
-12	1 1/16-12	1680 ± 75	140 ± 6
-16	1 5/16 - 12	2520 ± 100	210 ± 8
-20	1 5/8 - 12	3100 ± 150	260 ± 12
-24	1 7/8 - 12	3800 ± 150	315 ± 12

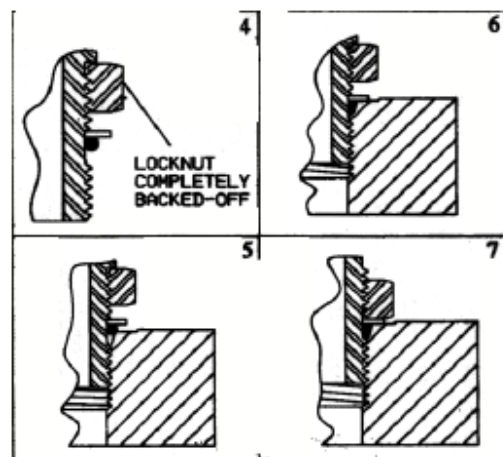

NOTE - ft-lb may be converted to Newton Meters by multiplying by 1.35582.

NOTE - in-lbs may be converted to Newton Meters by multiplying by 0.11298.

WARRANTY

Limited Warranty

Except for the Excluded Products as described below, all new products are warranted to be free from defects in material and/or workmanship during the Warranty Period, in accordance with and subject to the terms and conditions of this Limited Warranty.

1. Excluded Products. The following products are excluded from this Limited Warranty:

(a) Any cable, part that engages with the ground (i.e. sprockets), digging chain, bearing, teeth, tamping and/or demolition head, blade cutting edge, pilot bit, auger teeth and broom brush that either constitutes or is part of a product.

(b) Any product, merchandise or component that, in the opinion of Spartan Equipment, has been (i) misused; (ii) modified in any unauthorized manner; (iii) altered; (iv) damaged; (v) involved in an accident; or (vi) repaired using parts not obtained through Spartan Equipment.

2. Warranty Period. The Limited Warranty is provided only to those defects that occur during the Warranty Period, which is the period that begins on the first to occur of: (i) the date of initial purchase by an end-user, (ii) the date the product is first leased or rented, or (iii) the date that is six (6) months after the date of shipment by Spartan Equipment as evidenced by the invoiced shipment date (the "Commencement Date") and ends on the date that is twelve (12) months after the Commencement Date.

3. Terms and Conditions of Limited Warranty. The following terms and conditions apply to the Limited Warranty hereby provided:

(a) Option to Repair or Replace. Spartan Equipment shall have the option to repair or replace the product.

(b) Timely Repair and Notice. In order to obtain the Limited Warranty, (i) the product must be repaired within thirty (30) days from the date of failure, and (ii) a claim under the warranty must be submitted to Spartan Equipment in writing within thirty (30) days from the date of repair.

(c) Return of Defective Part or Product. If requested by Spartan Equipment, the alleged defective part or product shall be shipped to Spartan Equipment at its manufacturing facility or other location specified by Spartan Equipment, with freight PRE-PAID by the claimant, to allow Spartan Equipment to inspect the part or product.

Claims that fail to comply with any of the above terms and conditions shall be denied.

LIMITATIONS AND EXCLUSIONS.

THIS LIMITED WARRANTY IS IN LIEU OF ALL OTHER WARRANTIES, EXPRESS OR IMPLIED, INCLUDING WITHOUT LIMITATION THE WARRANTIES OF MERCHANTABILITY, FITNESS FOR A PARTICULAR PURPOSE AND ANY WARRANTY BASED ON A COURSE OF DEALING OR USAGE OF TRADE.

IN NO EVENT SHALL SPARTAN EQUIPMENT BE LIABLE FOR CONSEQUENTIAL OR SPECIAL DAMAGES.

IN NO EVENT SHALL SPARTAN EQUIPMENT BE LIABLE FOR ANY LOSS OR CLAIM IN AN AMOUNT IN EXCESS OF THE PURCHASE PRICE, OR, AT THE OPTION OF SPARTAN EQUIPMENT, THE REPAIR OR REPLACEMENT, OF THE PARTICULAR PRODUCT ON WHICH ANY CLAIM OF LOSS OR DAMAGE IS BASED. THIS LIMITATION OF LIABILITY APPLIES IRRESPECTIVE OF WHETHER THE CLAIM IS BASED ON BREACH OF CONTRACT, BREACH OF WARRANTY, NEGLIGENCE OR OTHER CAUSE AND WHETHER THE ALLEGED DEFECT IS DISCOVERABLE OR LATENT.

February 10, 2010