

Stump Planer 250mm - 2in Hex. - Parts List

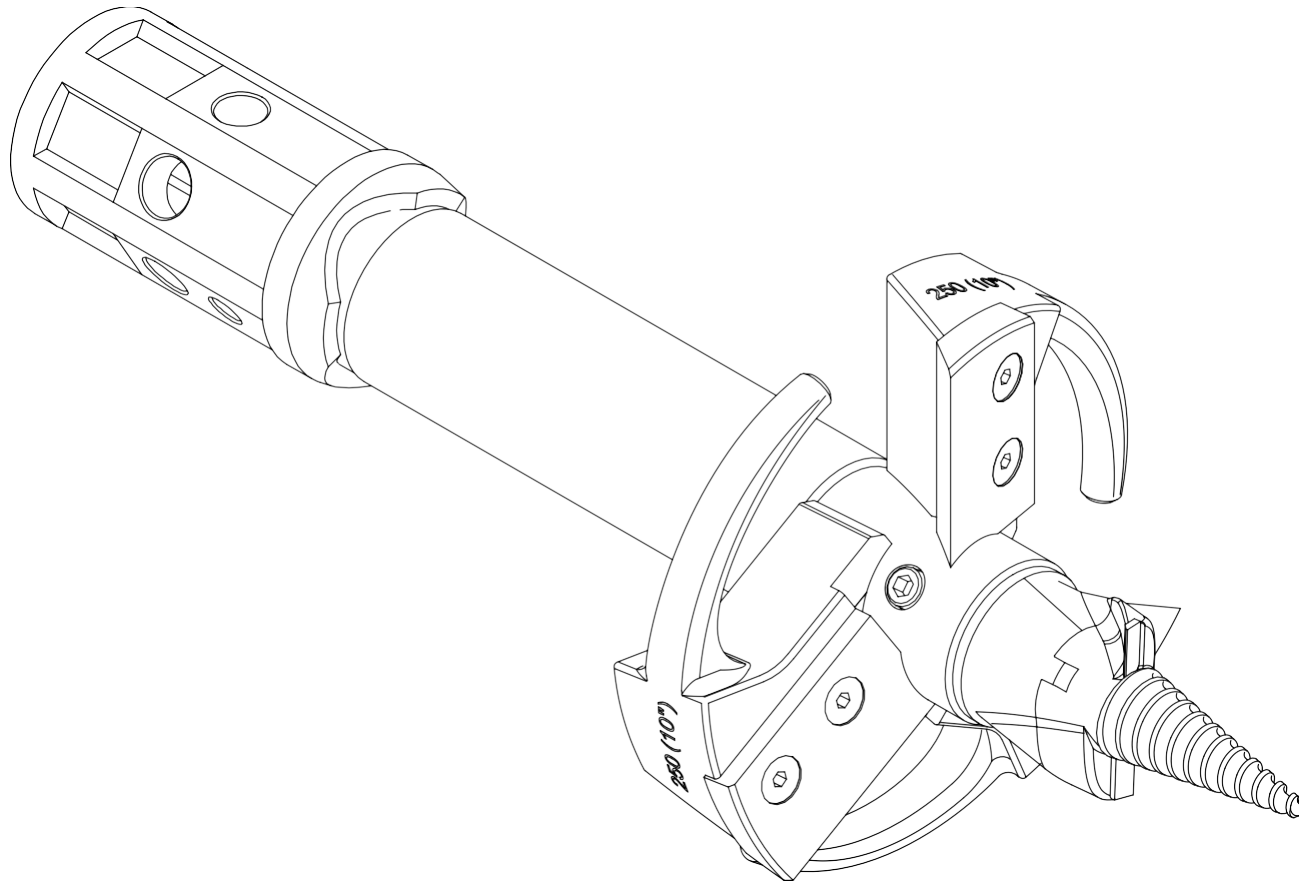



Stump Planer 250mm - 2in Hex. - Parts List

FOREWORD

This document is the property of Spartan Equipment, and the information contained herein is confidential to the company. The contents of the document must not be reproduced or disclosed wholly or in part or used for purposes other than that for which it has been supplied, without the prior written permission of Spartan Equipment.

This manual has been written in the standard English Language. Spartan Equipment accepts no responsibility or liability for customer or any other third-party translations of this manual into other languages, or for any incidents arising from such translation.

Spartan Equipment operates a policy of continuous product improvement, and actively encourages feedback on user manuals. If you wish to comment on the contents of this manual, please send your comments using the feedback form provided. Please copy and complete the hard copy form on the back page of this manual.

SAFETY

Spartan Equipment Earth Drill Units have been designed for use with specific Spartan Equipment mounting frames, augers, auger extensions and auger wear parts. Provided these are used and maintained correctly, they will provide a safe and reliable method of boring holes in the earth.

Use of this product following unauthorized modifications or repairs, use by untrained personnel, by implementing unsafe systems of work, by making modifications to product supplied or through operation in any manner not intended by Spartan Equipment could result in death, serious injury, damage to property or the product itself, and will invalidate any product validation or warranty. Spartan Equipment accepts no responsibility whatsoever for such modifications, repair or use.

LIMITED WARRANTY

Spartan Equipment products are warranted to be free in materials and workmanship under normal use and service, for a period of one year from the date of purchase, when operated and maintained in accordance with the operating and maintenance instructions supplied with the unit. Warranty is limited to the repair of the product and/or replacement of parts.

This warranty is extended only to the original purchaser and is not transferable.

Repairs must be done by an authorized dealer. Products will be returned to the dealer at the customer's expense. Include the original purchase receipt with any claim.

This warranty does not cover the following:

- 1) Normal maintenance or adjustments.
- 2) Normal replacement or wearable and service parts.
- 3) Consequential damage, indirect damage, or loss of profits.
- 4) Damages resulting from:
 - Misuse, negligence, accident, theft or fire.
 - Use of improper or insufficient fuel, fluids or lubricants.
 - Modifications, alteration, tampering or improper repair performed by parties other than an authorized dealer.
 - Any device or accessories installed by parties other than an authorized dealer.

Stump Planer 250mm - 2in Hex. - Parts List

THE MACHINERY DIRECTIVE

The Machinery Directive 2006/42/EC (formerly 98/37/EEC) provides the harmonization of the essential health and safety requirements for machinery, through a combination of mandatory health and safety requirements and voluntary harmonized standards. Such directives apply only to products that are intended to be placed on or put into service in the market for the first time.

The manufacturer or the authorized representative must draw up a 'Declaration of Conformity'.

Declaration of Conformity

Where Earth Drill Units are supplied in conjunction with Spartan Equipment manufactured mounting frames and augers to form an Earth Drill Assembly, Spartan Equipment has control over the suitability of the parts supplied. To show this and meet the lawful requirements of the Machinery Directive a Declaration of Conformity is issued and a CE mark is applied to the assembly.

SYMBOLS AND ABBREVIATIONS

The symbols that follow are used within this publication



Safety Glasses to be worn



Gloves/hand protection to be used



Safety shoes to be worn



Torque Tightening required

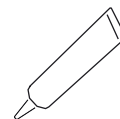

Thread treatment required



Refer to Interchangeability Chart

Stump Planer 250mm - 2in Hex. - Parts List

ILLUSTRATED PARTS LIST.

- A The Illustrated Parts List helps the supply procedure and the identification of replacement component parts.
- B The Detailed Parts List is divided into seven columns:
- The first column gives the item number of each detailed part contained in the illustration. An item number prefixed by a (-), shows that the item is not illustrated.
 - The second column gives the part number by which the item is identified.
 - The third column gives the description of the component. The description will be preceded by one or more dots (•).
 - The fourth column gives the quantity of each item in the complete assembly.
 - The fifth column shows the torque tightening required for the item.
 - The sixth column shows the thread treatment required for the item.
 - The seventh column refers to any additional information required for the part or assembly.
- C Only those items with full dots (•) can be ordered as spares. Items with empty dots (eg •◆) are shown only for clarity of assembly and cannot be ordered as spares.

The abbreviations that follow are used within this publication

AR	As Required
BSP	British Standard Pipe Thread
cc	Cubic Centimeters
Kg	Kilograms
L	Liters
LPM	Liters Per Minute
Mm	Millimeters
Nm	Newton Meters
UNC	Unified Coarse Thread
GPM	Gallons Per Minute
G	Gallons
lbs	Pounds
ft-lbs	Foot Pounds

Stump Planer 250mm - 2in Hex. - Parts List

Ref. SP25H-001-2

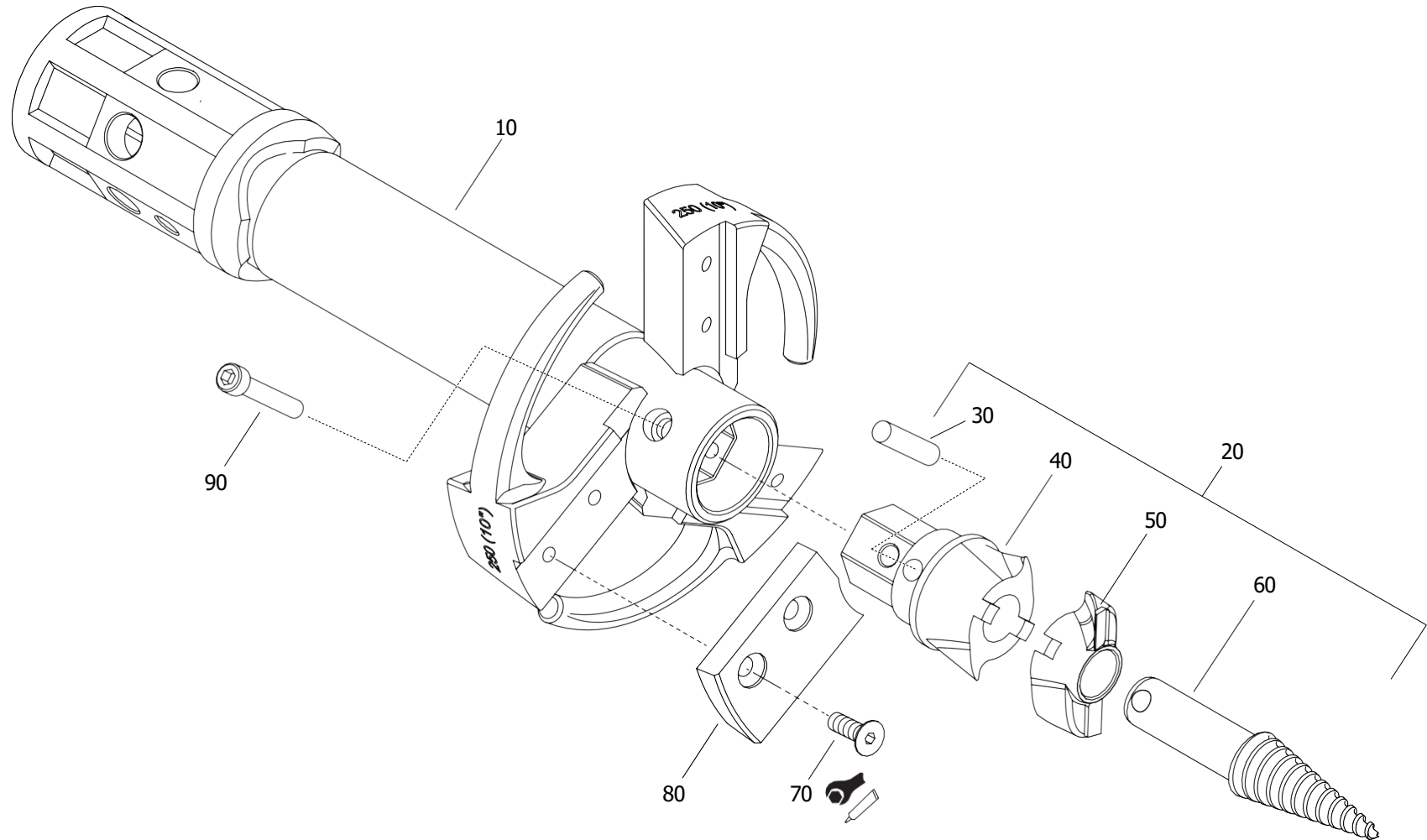



Stump Planer 250mm - 2in Hex. - Parts List

ITEM	PART NO.	DESCRIPTION	QTY	TORQUE LOAD	THREAD TREATMENT	NOTES
10	37-025035-3-FAB	• STUMP PLANER DIA 250 2" HEX HUB FAB	1			
20	37-1960	• STUMP PLANER PILOT HEAD ASSEMBLY	1			
30	37-1064	• DOWEL LOCK Ø12X53 LONG - STUMP PLANER	1			
40	37-1062	• CAST PILOT HEAD - STUMP PLANER	1			
50	37-1063-FAB	• STUMP PLANER - CAST PILOT HEAD - WITH BLADES	1			
60	37-1021	• PILOT - STUMP PLANER (REPLACEABLE)	1			
70	99-9144-030	• FIXING - CNSK SKT HD M10 x 30	6	29.5- 34 ft-lb (40- 46 Nm)	LOCTITE 243	
80	37-1027	• BLADE 250mm DIA STUMP PLANER	3			
90	99-9134-060	• FIXING - M10 x 60 SOCKET CAP SCREW (12.9) GRADE A	1			
						Ref. SP25H-001-2



Stump Planer 250mm - 2in Hex. - Parts List

Spartan Equipment Publication Feedback Form

Please copy this form and when complete return to the address below

Your Contact Details

Please enter your feedback in the field below :-

Name :-

Address :-

Telephone :-

Email :-

Publication Number

Publication Title

Issue/Rev Number

Spartan Equipment
(888) 888-1085
support@spartanequipment.com
www.spartanequipment.com

